



# SERVICE BULLETIN NO. MSB306-37/2 MSB320-08/2

## I. TECHNICAL DETAILS

### 1.1 Category:

**MANDATORY**

### 1.2 Airplanes affected:

#### **TCDS-No. 306 (FAA TC No. G33EU):**

CLUB ASTIR II

STANDARD ASTIR II

S/N 5001 - 5061 (with suffix "C")

S/N 5001 - 5061 (with suffix "S")

#### **TCDS-No. 320 (FAA TC No. G33EU):**

SPEED ASTIR II

SPEED ASTIR IIb

S/N 4001 - 4027

S/N 4028 - 4107

### 1.3 Time of Compliance:

Not later than 31 December 2003

### 1.4 Subject:

ATA-Code: ---

#### **Modification of the Canopy Jettison System**

### 1.5 Reason:

A research report issued by the college of Aachen has shown, that the installation of a canopy joint, installed in the rear, represents the ideal solution for a canopy jettison system. As such a canopy joint is already installed in the affected gliders, the canopy jettison system can be improved.

Standard Astir II  
Club Astir II  
SPEED ASTIR II  
SPEED ASTIR IIb



**1.6 Concurrent documents:**

None

**1.7 Approval Note:**

The technical information contained in this document has been approved under the authority of JAA Design Organization Approval No. LBA.NJA.008.

**1.8 Accomplishment/ Instructions**

1.8.1 **A.** At the RH canopy frame or seat shell the placard “Canopy jettison and Exit” must be replaced against the new placard (see manual pages “Emergency Procedures”):

**Canopy jettison and exit**

- a) Open the canopy,  
pull red canopy handles and turn 90° inwards!
- b) release the canopy,  
lift up the canopy with red handles to release canopy!
- c) unbuckle seat harness
- d) EXIT over left or right side
- e) Wait 1 - 3 seconds before pulling the rip cord

CAUTION: The canopy will be swept away by the wind force turning over the rear joint !

**B.** At the LH and RH canopy both placards “Canopy Catch” must be replaced by the new placards (“Canopy Catch + Emergency Jettison”):

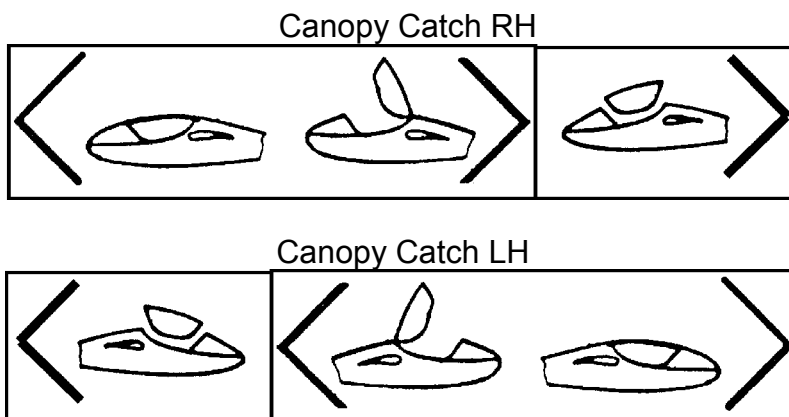

Standard Astir II  
Club Astir II  
SPEED ASTIR II  
SPEED ASTIR IIb



1.8.2 The canopy jettison operating lever including operating cable must be removed as follows (refer to illustration on page 4):

- remove the RH cockpit covering
- remove bolt (37)
- cut-off cable (57) and remove adjusting screw (48) and remove completely operating cable (64)
- remove safety wire (69)
- remove nut (49) and operating lever (27)
- cut-off cable (57) from canopy joint
- remove cable rest with socket (62) and nipple (23)
- install RH cockpit covering
- remove placard "Canopy Jettison" from canopy jettison operating lever



NOTE: The canopy can be removed for maintenance purposes by operating the red ball knob (58)

1.8.3 In the Flight and Maintenance Manuals the following revisions must be incorporated:

**G 102 CLUB UND STANDARD II:**

- Flight Manual: Revision 3, 13.06.03
- Maintenance Manual: Revision 1, 13.06.03

Italian issue:

- Flight Manual: Revision 3, 13.06.03

Canadian Issue:

- Flight Manual: Revision 3, 13.06.03
- Maintenance Manual: Revision 2, 13.06.03

**G 104 SPEED ASTIR II / IIb:**

- Flight Manual: Revision 3, 13.06.03
- Maintenance Manual: Revision 2, 13.06.03

**1.9 Repetitive Actions**

None

**1.10 Mass (Weight) and CG:**

negligible

Standard Astir II  
Club Astir II  
SPEED ASTIR II  
SPEED ASTIR IIb

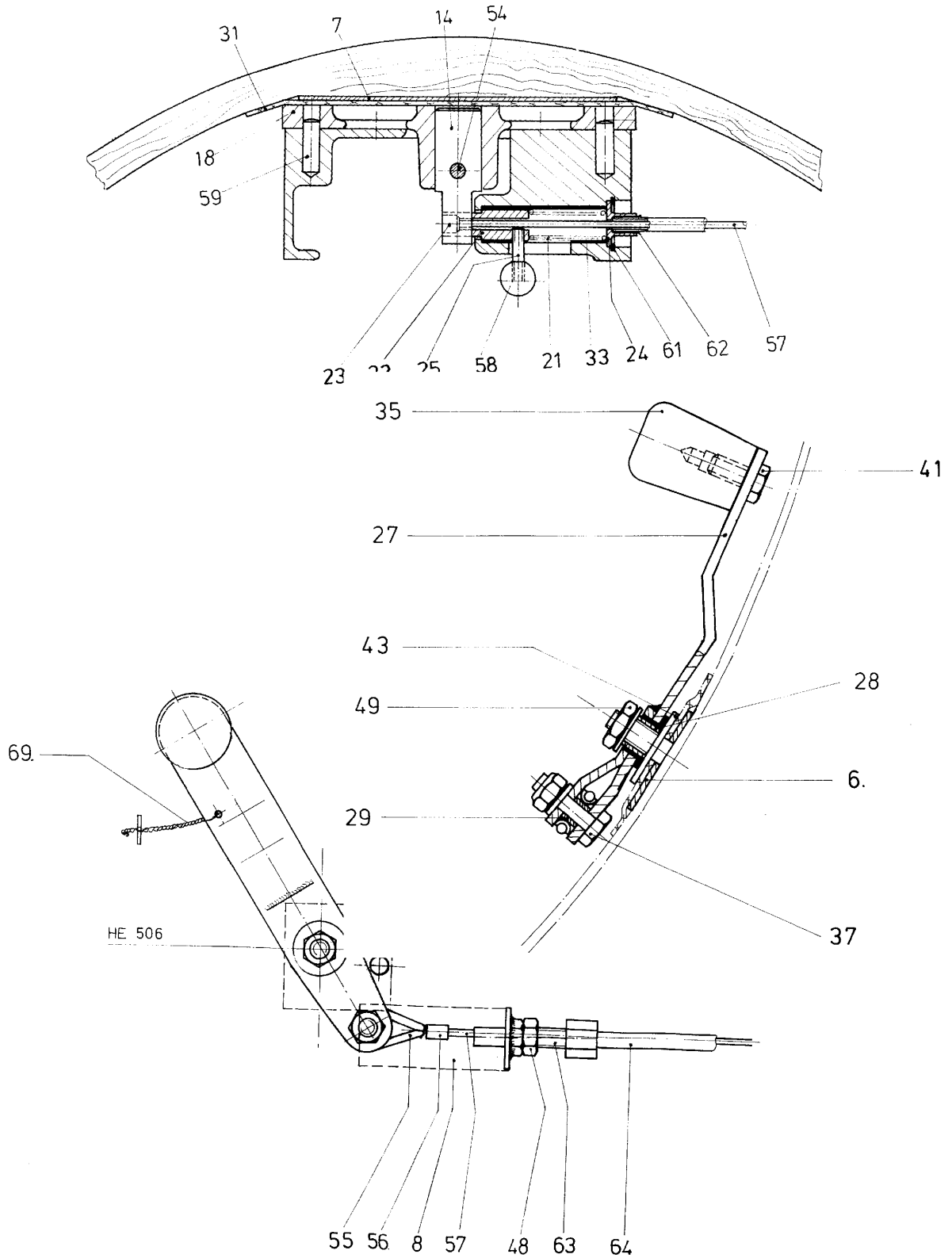

Standard Astir II  
Club Astir II  
SPEED ASTIR II  
SPEED ASTIR IIb

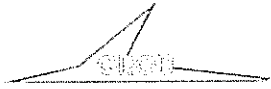

## II. PLANNING INFORMATION

### 2.1 Material & Availability:

1. The exchange pages for the manuals (format DIN A5) and the palcards according to 1.8.2 are attached to the Service Bulletin.
2. The removed parts (lever etc.) may be disposed.

### 2.2 Special Tools:

N/A

### 2.3 Labour costs:

approx. 1 hour

### 2.4 Reference documents:

N/A

### 2.6 Credit:

N/A

## III. REMARKS

- 3.1 The correct execution of the instructions may be performed by a competent person and has to be certified in the logbook by an authorised inspector.
- 3.2 If you have sold your aircraft in the meantime, would you kindly pass this information on to the new owner and forward his address and aircraft S/N to us.
- 3.3 For questions and assistance please contact:  
Rudi Vodermeier , Head of Product Support,  
phone: +49 8268 998139  
fax: +49 8268 998200  
e-mail: [productsupport@grob-aerospace.de](mailto:productsupport@grob-aerospace.de)

Anerkannt durch  
Luftfahrt-Bundesamt



13. AUG. 2003

Standard Astir II  
Club Astir II  
SPEED ASTIR II  
SPEED ASTIR IIb