

## SERVICE BULLETIN NO. MSB 315-76/1 SERVICE BULLETIN NO. MSB 869-27/1

### I. TECHNICAL DETAILS

#### 1.1 Category:

Mandatory

#### 1.2 Airplanes affected:

TCDS: 315                      FAA TCDS: G39EU

| Model                | Serial Number  |
|----------------------|----------------|
| G 103 TWIN II        | 3730-3878      |
| G 103A TWIN II ACRO  | 3730-34078 (K) |
| G 103C TWIN III ACRO | 34101-34203    |
| G 103C TWIN III      | 36001-36014    |

TCDS: 869                      FAA TCDS: G57EU

| Model              | Serial Number |
|--------------------|---------------|
| G 103C TWIN III SL | 35001-35051   |

#### 1.3 Time of Compliance:

Not later than 30 September 2008

#### 1.4 Subject:

ATA-Code:                      27-60  
   Airbrake Control

#### 1.5 Reason:

GROB received a report that a bolt in the airbrake control was found failed during a pre-flight inspection on a G 103C TWIN III ACRO.

During an extensive investigation (metallurgical investigation) a double sided fatigue crack was found as root cause. As the bolt is insignificantly stressed by cyclic bending the crack was probably caused by mean stress supported by a bolt torque exceeding the limit.

As a precautionary action the immediate exchange of the bolt and installation with the correct bolt torque is mandatory.

G 103

### **1.6 Concurrent documents:**

Maintenance Manual of the affected models

### **1.7 Approval Note:**

The technical information contained in this document has been approved under the authority of EASA Design Organisation Approval No. EASA.21J.030.

### **1.8 Accomplishment/ Instructions**

- 1.8.1 De-rig aircraft.
- 1.8.2 Remove rear seat.
- 1.8.3 Remove inner main wheel fairing.
- 1.8.4 Remove access cover behind the rear seat.
- 1.8.5 Remove bolt LN9037-M6x60 from the airbrake bell crank 103B-4437 and install new bolt. Use new locking nut LN9348-M6 (see figure on page 4). Bolt torque: 6.4 Nm (4.72lbs.ft)

Note: Alternatively bolt LN9037-M6x62 may be installed. Thereby use additional washer LN9037-6,4 under the bolt head.

- 1.8.6 Check visually all parts of the airbrake bell crank including the attachment parts for any damage (if required use magnifying glass 10x). Damaged parts must be replaced (see also table on page 4).
- 1.8.7 Install access cover behind the rear seat.
- 1.8.8 Install inner main wheel fairing.
- 1.8.9 Check the airbrake locking force of the LH and RH wing using a spring balance. They must be equal for both sides (guidance value: 10±2 daN, (22.48±4.5 lbs)) and the locking must be clearly noticable. If necessary adjust the force as follows:
  - force too high: lengthen the airbrake rod (between airbrake and over centre lever, approx. ½ to 1 turn)
  - force too low: shorten the airbrake rod (between airbrake and over centre lever, approx. ½ to 1 turn)
  - repeat measurement and if necessary repeat adjustment
  - rig wings
  - check controls for free and easy movement for correct sense of deflection.
- 1.8.10 Check the airbrake locking force at the operating lever in the front cockpit. The guidance value is 10±2 daN, (22.48±4.5 lbs). It must not exceed 15 – 20 daN (33.7 – 44.96lbs).

### **1.9 Repetitive Actions**

N/A

**1.10 Mass (Weight) and CG:**

N/A

**II. PLANNING INFORMATION**

**2.1 Material & Availability:**

- qty 1 bolt LN 9037-M6x60 or LN 9037-M6x62
- qty. 1 locking nut LN9348-M6
- qty. 2 washer LN9025-6,4

The required material can be ordered from Grob Aerospace GmbH. Please advise serial number, flight hours and number of landings.

**2.2 Special Tools:**

N/A

**2.3 Labour costs:**

Approx. 1 hour for bolt replacement

**2.4 Reference documents:**

N/A

**2.5 Credit:**

N/A

**III. REMARKS**

**3.1** The correct execution of the instructions must be performed by an authorized aviation workshop or a licensed inspector and has to be certified in the logbook by an authorised inspector.

**3.2** If you have sold your aircraft in the meantime, would you kindly pass this information on to the new owner and forward his address and aircraft S/N to us.

**3.3** For questions and assistance please contact:

Rudi Vodermeier, Head of Customer Service  
phone: +49 8268 998139  
fax: +49 8268 998200  
e-mail: [productsupport@grob-aerospace.de](mailto:productsupport@grob-aerospace.de)

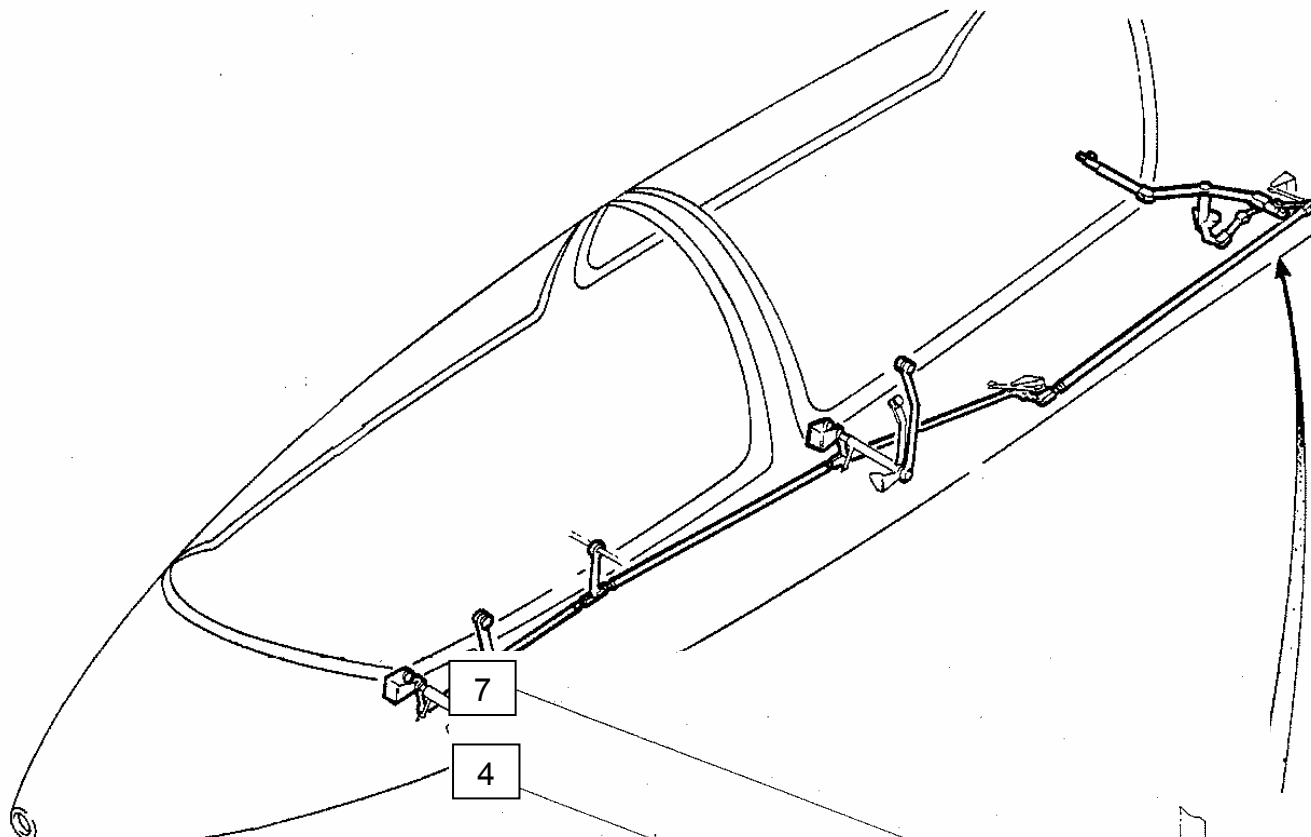

| Item | Qty. | Name           | P/N           |
|------|------|----------------|---------------|
| 1    | 1    | Airbrake lever | 103B-4438     |
| 2    | 1    | Elevator lever | 103B-4439     |
| 3    | 1    | Bracket        | 102C3-4259    |
| 4    | 1    | Tube           | 102C3-4261.04 |
| 5    |      |                |               |
| 6    | 5    | Washer         | LN 9025-6,4   |
| 7    | 1    | Bolt           | LN9037-M6x60  |
| 8    | 1    | Nut            | LN9348-M6     |

